



www.esaunggul.ac.id

TOPIK DALAM INFORMATION RETRIEVAL
PROGRAM STUDI MAGISTER ILMU KOMPUTER
FAKULTAS ILMU KOMPUTER
Pertemuan – 3 #7329-Dr. Gerry Firmansyah

Crawling and web indexes

Sumber : Information Retrieval, Pandu Nayak and Prabhakar Raghavan

Basic crawler operation

- Begin with known “seed” URLs
- Fetch and parse them
 - Extract URLs they point to
 - Place the extracted URLs on a queue
- Fetch each URL on the queue and repeat

Crawling picture

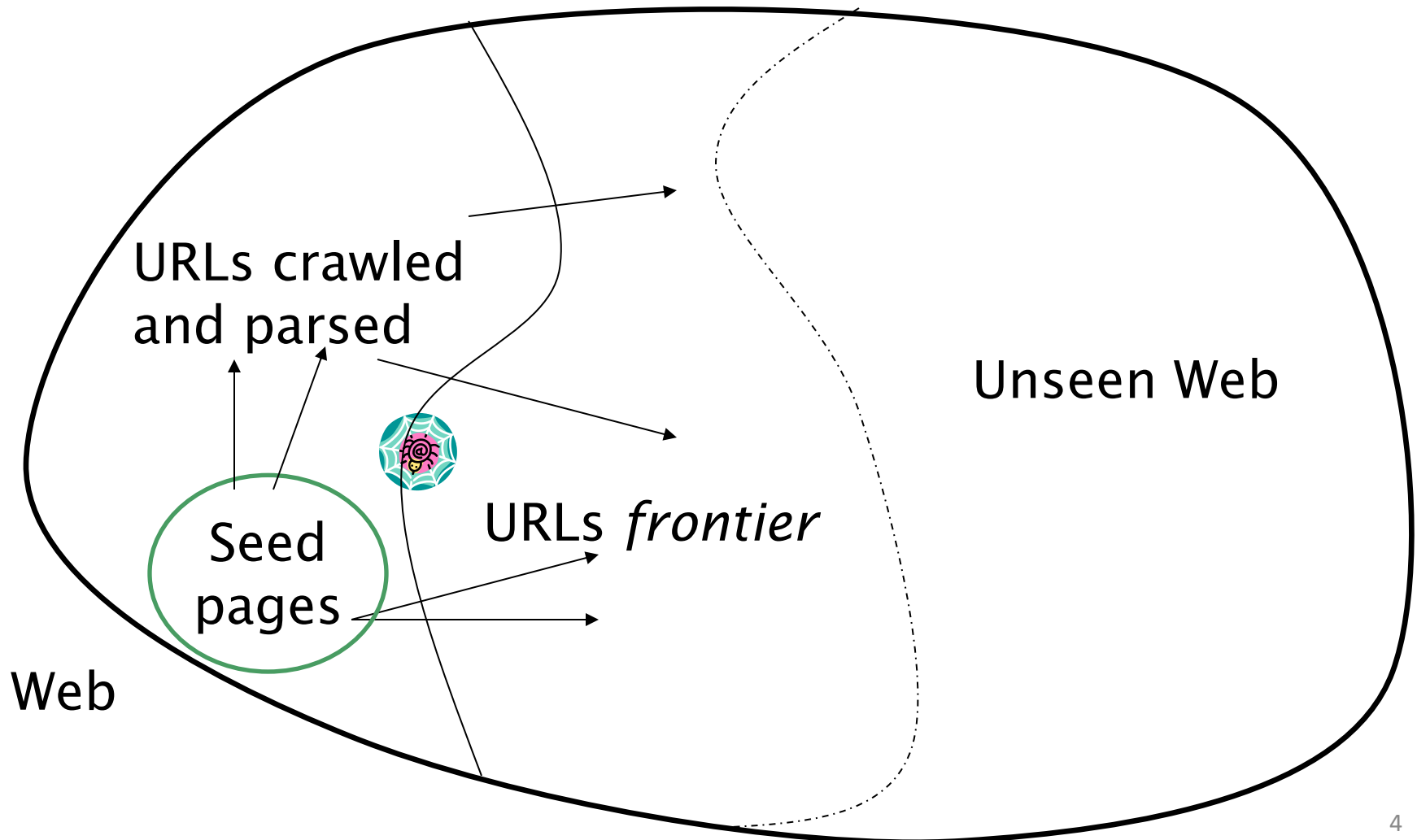

Simple picture – complications

- Web crawling isn't feasible with one machine
 - All of the above steps distributed
- **Malicious pages**
 - Spam pages
 - Spider traps – incl dynamically generated
- Even non-malicious pages pose challenges
 - Latency/bandwidth to remote servers vary
 - Webmasters' stipulations
 - How "deep" should you crawl a site's URL hierarchy?
 - Site mirrors and duplicate pages
- **Politeness – don't hit a server too often**

What any crawler *must* do

- Be Polite: Respect implicit and explicit politeness considerations
 - Only crawl allowed pages
 - Respect *robots.txt* (more on this shortly)
- Be Robust: Be immune to spider traps and other malicious behavior from web servers

What any crawler *should* do

- Be capable of distributed operation: designed to run on multiple distributed machines
- **Be scalable: designed to increase the crawl rate by adding more machines**
- Performance/efficiency: permit full use of available processing and network resources

What any crawler *should* do

- Fetch pages of “higher quality” first
- Continuous operation: Continue fetching fresh copies of a previously fetched page
- Extensible: Adapt to new data formats, protocols

Updated crawling picture

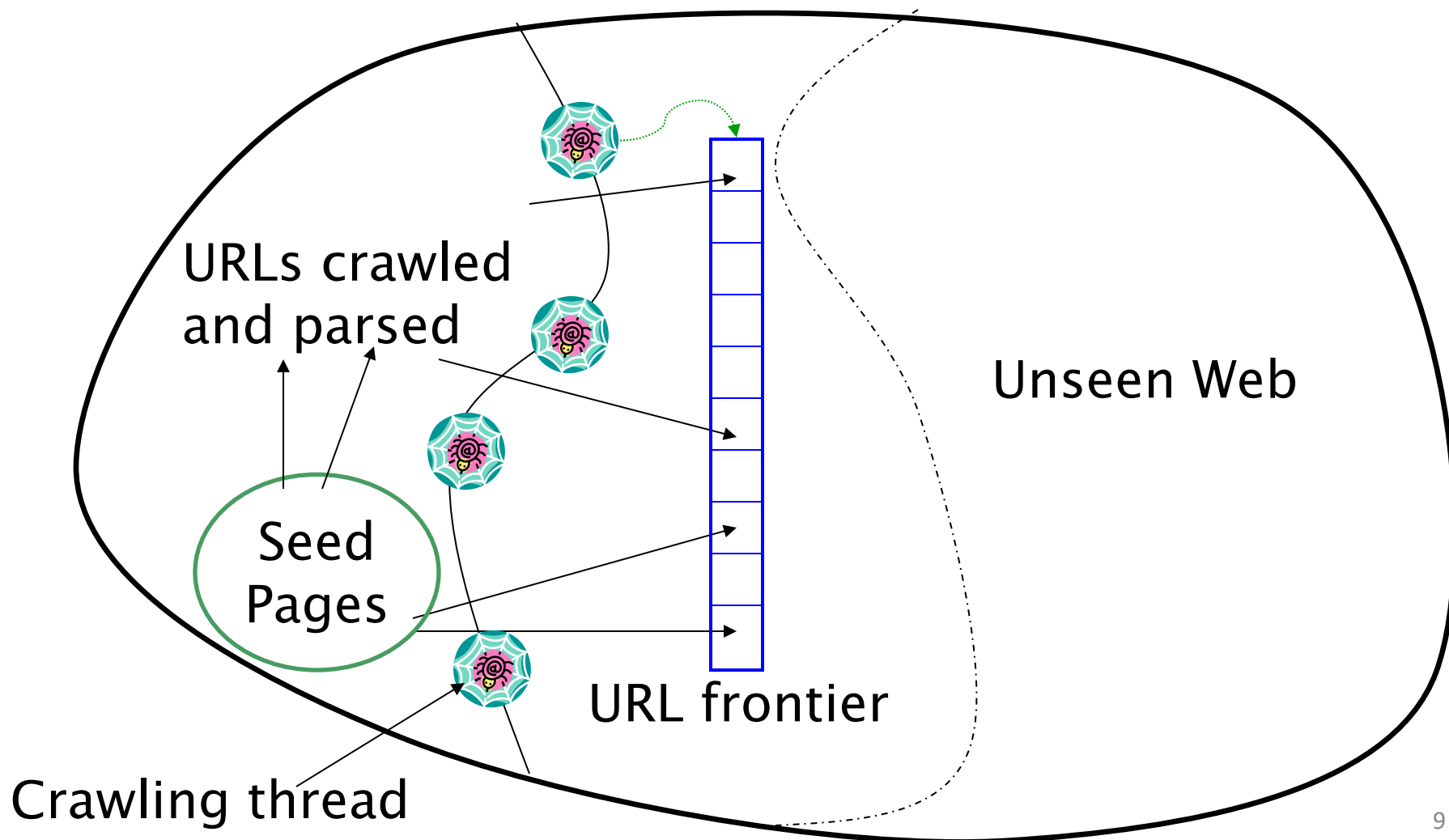

URL frontier

- Can include multiple pages from the same host
- **Must avoid trying to fetch them all at the same time**
- Must try to keep all crawling threads busy

Explicit and implicit politeness

- Explicit politeness: specifications from webmasters on what portions of site can be crawled
 - robots.txt
- Implicit politeness: even with no specification, avoid hitting any site too often

Robots.txt

- Protocol for giving spiders (“robots”) limited access to a website, originally from 1994
 - www.robotstxt.org/wc/norobots.html
- Website announces its request on what can(not) be crawled
 - For a server, create a file `/robots.txt`
 - This file specifies access restrictions

Robots.txt example

- No robot should visit any URL starting with `"/yoursite/temp/"`, except the robot called `"searchengine"`:

```
User-agent: *
```

```
Disallow: /yoursite/temp/
```

```
User-agent: searchengine
```

```
Disallow:
```

Processing steps in crawling

- Pick a URL from the frontier
- Fetch the document at the URL
- Parse the URL
 - Extract links from it to other docs (URLs)
- Check if URL has content already seen
 - If not, add to indexes
- For each extracted URL
 - Ensure it passes certain URL filter tests
 - Check if it is already in the frontier (duplicate URL elimination)

← Which one?

E.g., only crawl .edu,
obey robots.txt, etc.

Basic crawl architecture

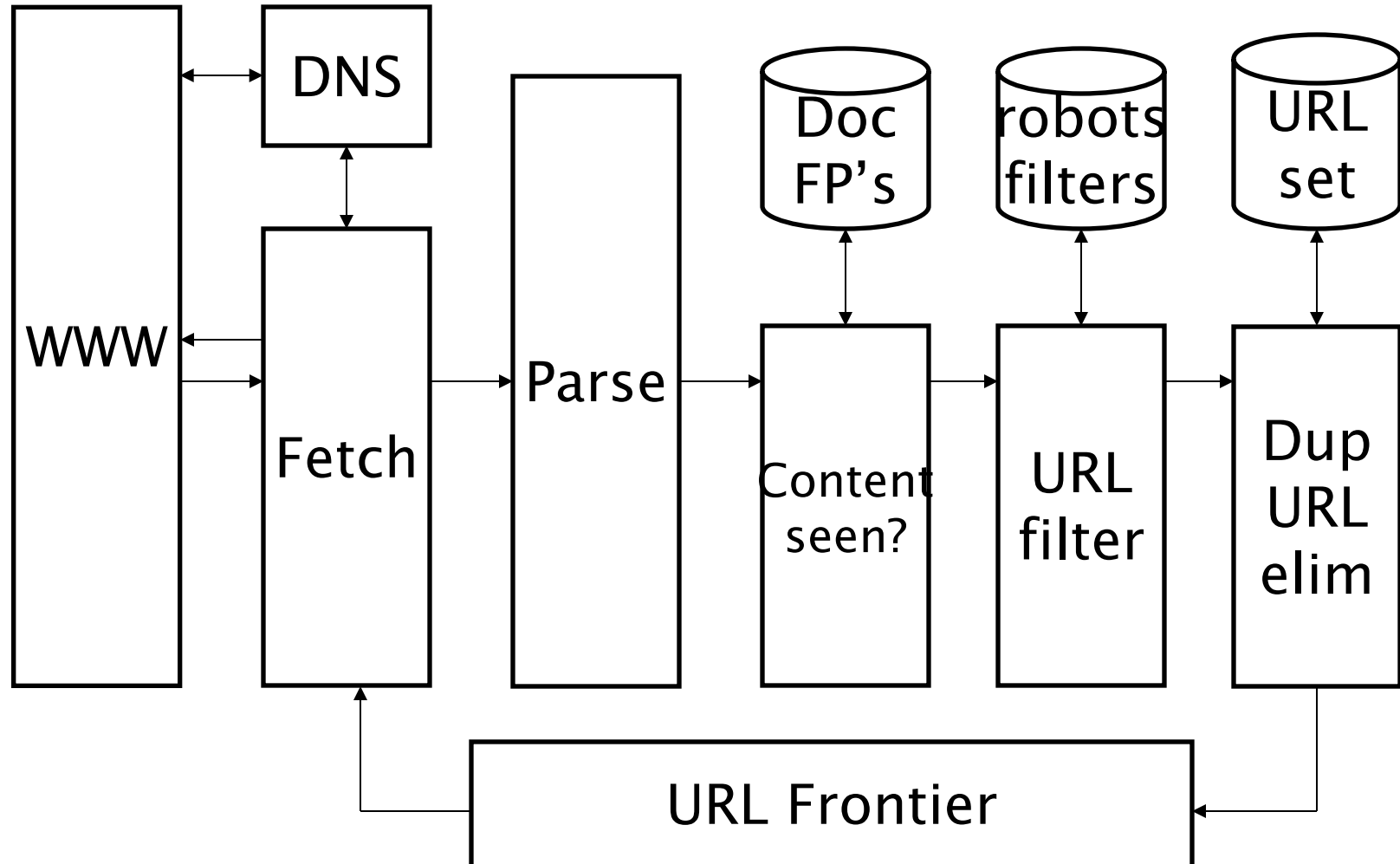

DNS (Domain Name Server)

- A lookup service on the internet
 - Given a URL, retrieve its IP address
 - Service provided by a distributed set of servers – thus, lookup latencies can be high (even seconds)
- **Common OS implementations of DNS lookup are *blocking*: only one outstanding request at a time**
- Solutions
 - DNS caching
 - Batch DNS resolver – collects requests and sends them out together

Parsing: URL normalization

- When a fetched document is parsed, some of the extracted links are *relative* URLs
- E.g., http://en.wikipedia.org/wiki/Main_Page has a relative link to `/wiki/Wikipedia:General_disclaimer` which is the same as the absolute URL http://en.wikipedia.org/wiki/Wikipedia:General_disclaimer
- During parsing, must normalize (expand) such relative URLs

Content seen?

- Duplication is widespread on the web
- If the page just fetched is already in the index, do not further process it
- This is verified using document fingerprints or shingles

Filters and robots.txt

- Filters – regular expressions for URL's to be crawled/not
- Once a robots.txt file is fetched from a site, need not fetch it repeatedly
 - Doing so burns bandwidth, hits web server
- Cache robots.txt files

Duplicate URL elimination

- For a non-continuous (one-shot) crawl, test to see if an extracted+filtered URL has already been passed to the frontier
- For a continuous crawl – see details of frontier implementation

Distributing the crawler

- Run multiple crawl threads, under different processes – potentially at different nodes
 - Geographically distributed nodes
- Partition hosts being crawled into nodes
 - Hash used for partition
- How do these nodes communicate and share URLs?

Communication between nodes

- Output of the URL filter at each node is sent to the Dup URL Eliminator of the appropriate node

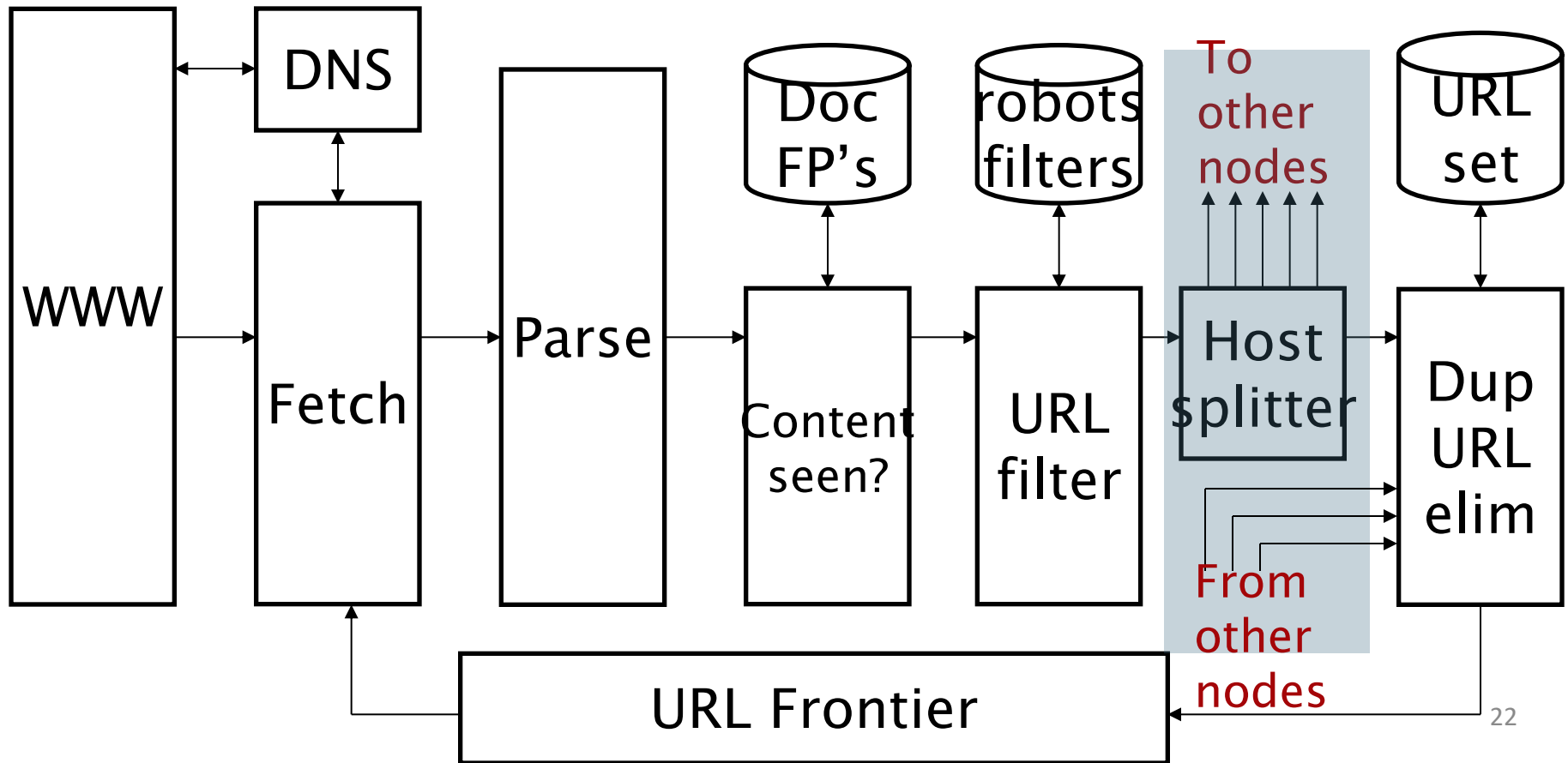

URL frontier: two main considerations

- Politeness: do not hit a web server too frequently
- Freshness: crawl some pages more often than others
 - E.g., pages (such as News sites) whose content changes often

These goals may conflict each other.

(E.g., simple priority queue fails – many links out of a page go to its own site, creating a burst of accesses to that site.)

Politeness – challenges

- Even if we restrict only one thread to fetch from a host, can hit it repeatedly
- Common heuristic: insert time gap between successive requests to a host that is \gg time for most recent fetch from that host

URL frontier: Mercator scheme

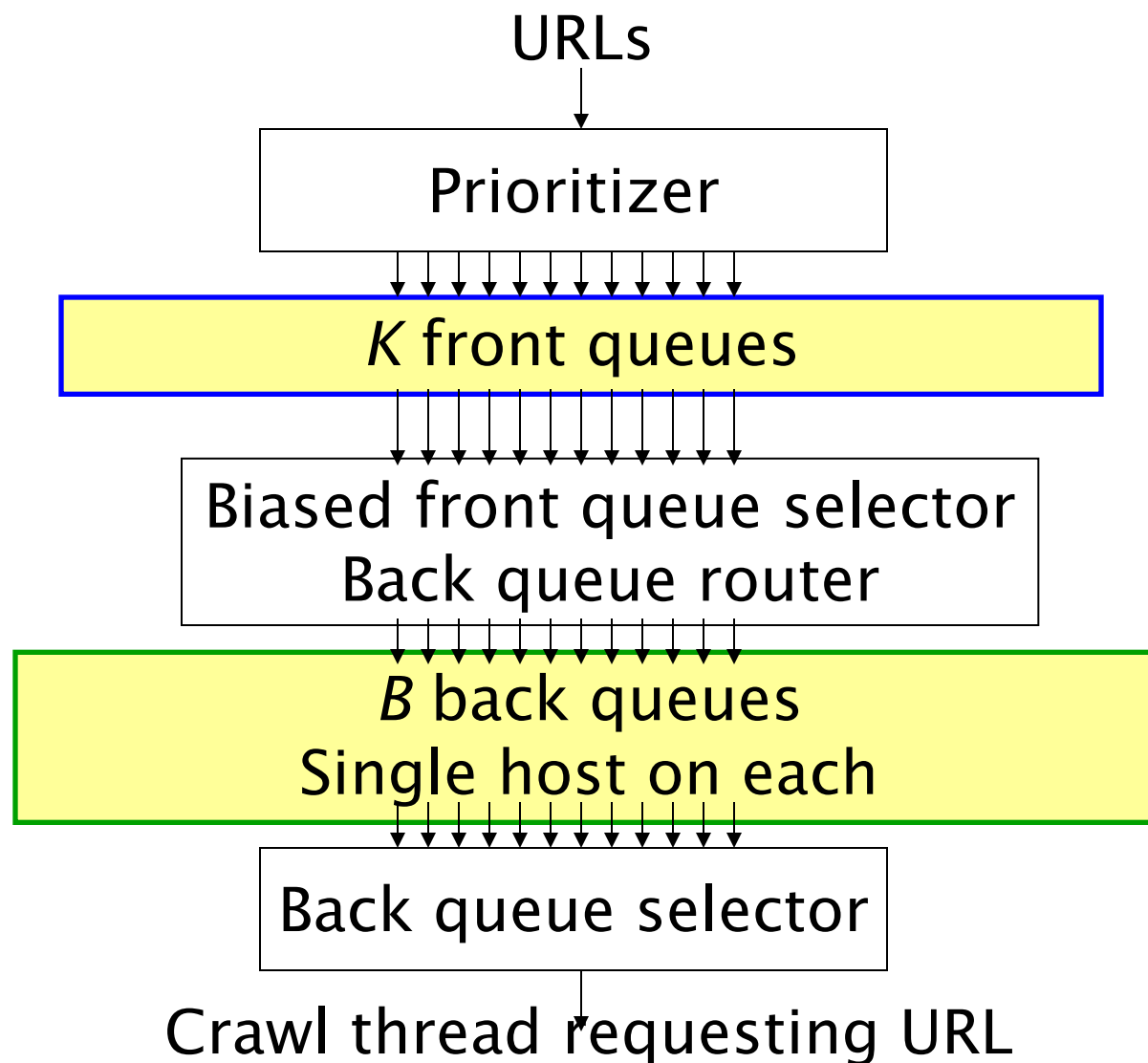

Mercator URL frontier

- URLs flow in from the top into the frontier
- **Front queues** manage prioritization
- **Back queues** enforce politeness
- Each queue is FIFO

Front queues

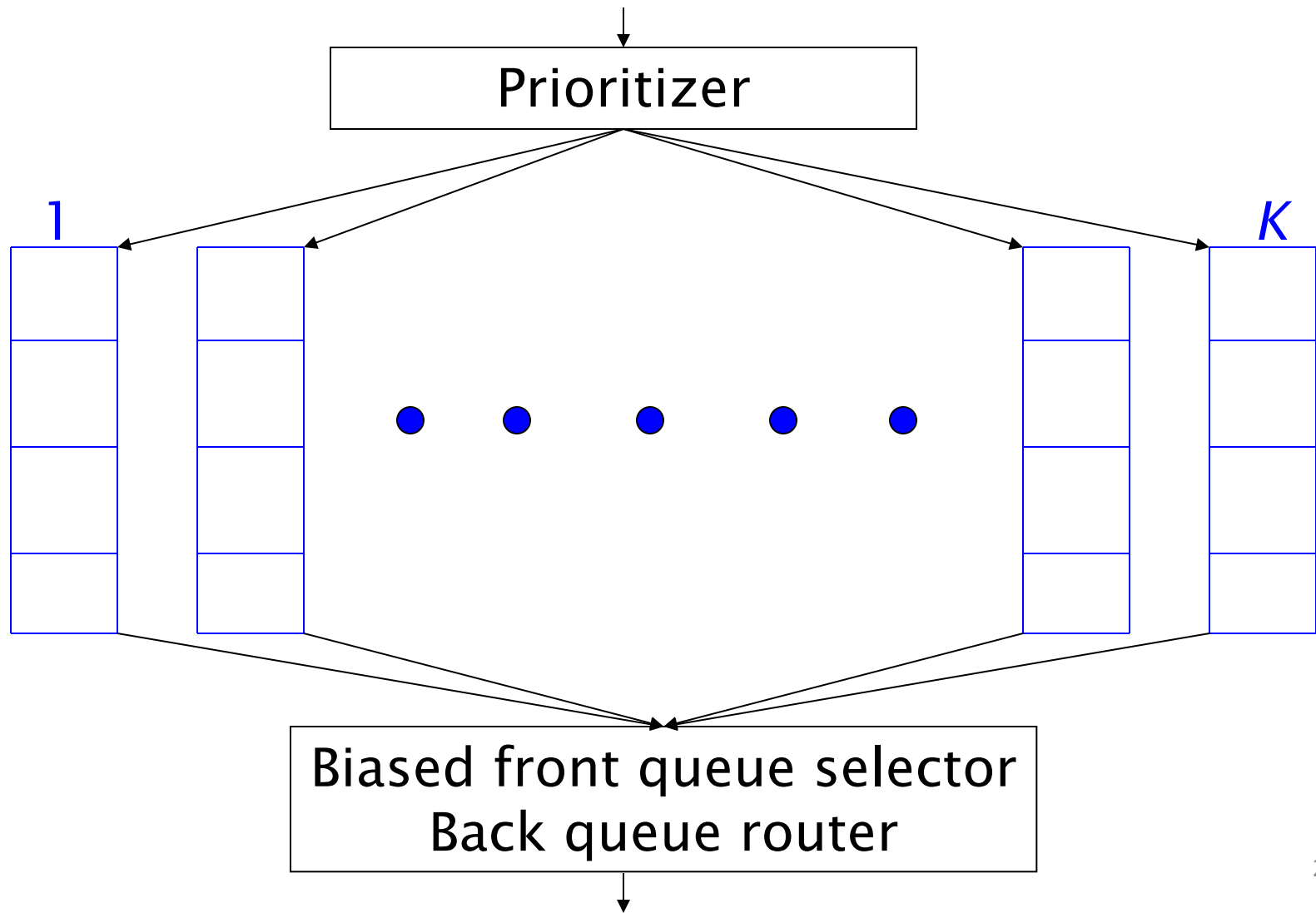

Front queues

- Prioritizer assigns to URL an integer priority between 1 and K
 - Appends URL to corresponding queue
- Heuristics for assigning priority
 - Refresh rate sampled from previous crawls
 - Application-specific (e.g., “crawl news sites more often”)

Biased front queue selector

- When a back queue requests a URL (in a sequence to be described): picks a **front queue** from which to pull a URL
- This choice can be round robin biased to queues of higher priority, or some more sophisticated variant
 - Can be randomized

Back queues

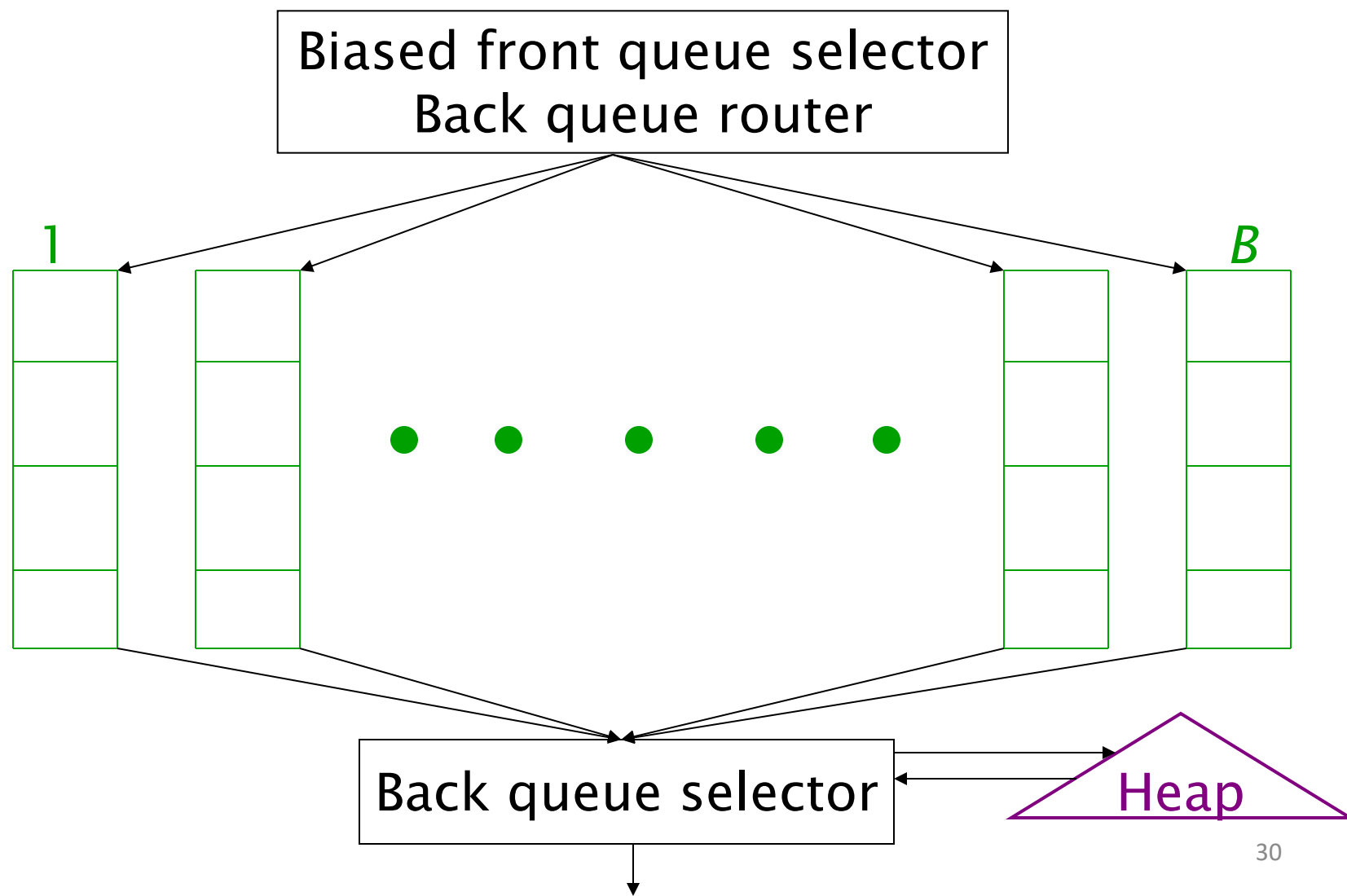

Back queue invariants

- Each back queue is kept non-empty while the crawl is in progress
- Each back queue only contains URLs from a single host
 - Maintain a table from hosts to back queues

| Host name | Back queue |
|-----------|------------|
| ... | 3 |
| | 1 |
| | <i>B</i> |

Back queue **heap**

- One entry for each back queue
- The entry is the earliest time t_e at which the host corresponding to the back queue can be hit again
- This earliest time is determined from
 - Last access to that host
 - Any time buffer heuristic we choose

Back queue processing

- A crawler thread seeking a URL to crawl:
- **Extracts the root of the heap**
- Fetches URL at head of corresponding back queue q (look up from table)
- **Checks if queue q is now empty – if so, pulls a URL v from front queues**
 - If there's already a back queue for v 's host, append v to q and pull another URL from front queues, repeat
 - Else add v to q
- **When q is non-empty, create heap entry for it**

Number of back queues B

- Keep all threads busy while respecting politeness
- Mercator recommendation: three times as many back queues as crawler threads

Resources

- IIR Chapter 20
- [Mercator: A scalable, extensible web crawler \(Heydon et al. 1999\)](#)
- [A standard for robot exclusion](#)